

Doc. No.			
Version:1.0	Audit No. : 0	In Total 7 Pages	1/7

PRODUCT SPECIFICATION



Model	OHBF52	Formulate	Tech.
Product name	Explosion-proof Linear Light	Proofreading	
Jiangsu Ouhui Lighting Co.,Ltd.		Review	
		Approve	
		Date	2020.05.30

Doc. No.			
Version:1.0	Audit No. : 0	In Total 7 Pages	2/7

1. Picture of Real Products



Doc. No.			
Version:1.0	Audit No. : 0	In Total 7 Pages	3/7

2.Features

2.1.Application Scenario

This product has good explosion-proof function, suitable for IIA, IIB, IIC explosive gas environment and various inflammable and explosive places, mainly used in railway, electric power, metallurgy, petroleum, petrochemical, chemical, steel, aviation, ship and each Efficient lighting in factories, stations, large facilities, venues and other places.

2.2.Product Features

2.2.1.Configuration: Using imported LED light source, the average service life is as long as 100,000 hours. The power supply adopts wide voltage processing, which can realize constant current output, has short circuit and over voltage protection functions, and greatly prolongs the service life of lamps and lanterns.

2.2.2.Heat dissipation: The radiator adopts an integrated streamlined structure, which can better increase heat conduction. The radiator is arranged in an internal and external circular array to improve its heat dissipation performance.

2.2.3.Anti-glare: toughened glass cover (transparent and frosted two options) anti-impact, anti-glare, light uniform and soft without shadows, transmittance up to 95% - 98%, suitable for various low-roof, platform, high-roof, high-roof and other places as fixed lighting.

2.2.4.Protection: IP66 protection level, corrosion protection level can reach WF2, the surface of the lamp body will never corrode, never rust.

2.2.5.Installation mode: Top ceiling, suspension ceiling, bent bar, vertical bar and other installation modes can be adopted as required.

2.2.6.Inlet port: Series and parallel connection of lamps and lanterns can be realized by adopting double inlet design.

Doc. No.			
Version:1.0	Audit No. : 0	In Total 7 Pages	4/7

3.Product parameters

ITEM	Symbol	Description	UNIT
Picture of real products			
Rated Voltage	VOLT	AC220	V
Power	P	20-60	W
Protection Level	IP	IP66	IP
Lighting Angle	θ	105.6	°
LED Qty	/	240	PCS
Chips	/	2835	
Anti-corrosion Grade	/	WF2	
Explosion Proof Grade	/	Exdemb IIC T6	
Light Efficiency	η	120	Lm/W
Frequency	f	50/60	Hz
Power Factor	PF	>0.95	PF
Operating Temperature	TOPR	-30~50	°C
Storage Temperature	TOPR	-30~50	°C
Light Source	/	led	
Correlate Color Temperature	Tc	3000-6500	K
Color Rendering Index	CRI	≥70	RA
LED'S Operating Life	LIFE	100000	Hours
Start-up Time	T	≤0.2	S
Executive Standard	/	GB3836. 2、 GB3836. 9	
Weight	/	4.9	KG
Size	/	1143*125*77	MM

Doc. No.			
Version:1.0	Audit No. : 0	In Total 7 Pages	5/7

4. Test Report

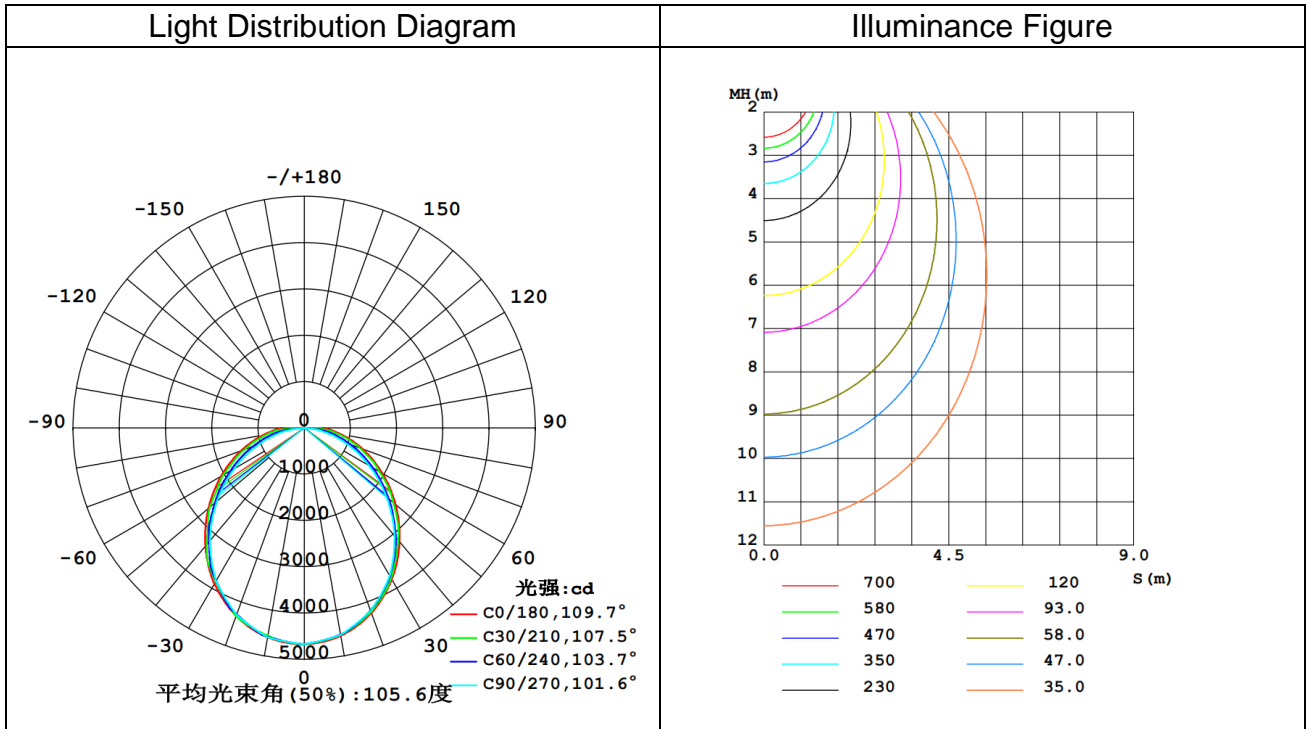

5. Dimensions

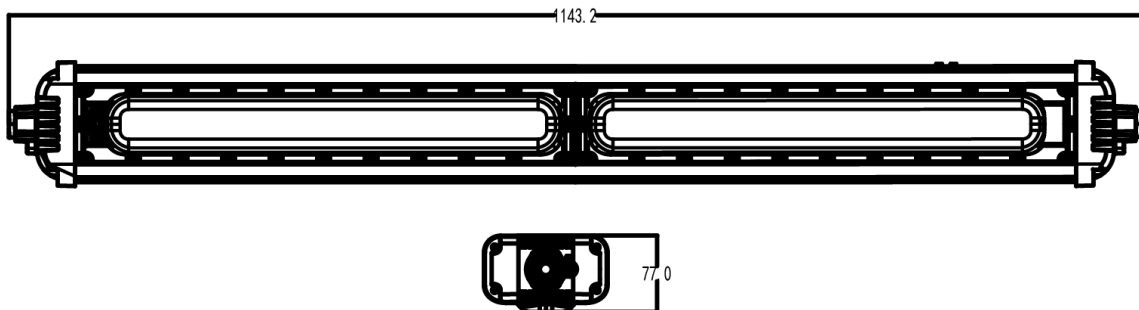

Doc. No.			
Version:1.0	Audit No. : 0	In Total 7 Pages	6/7

6.Install

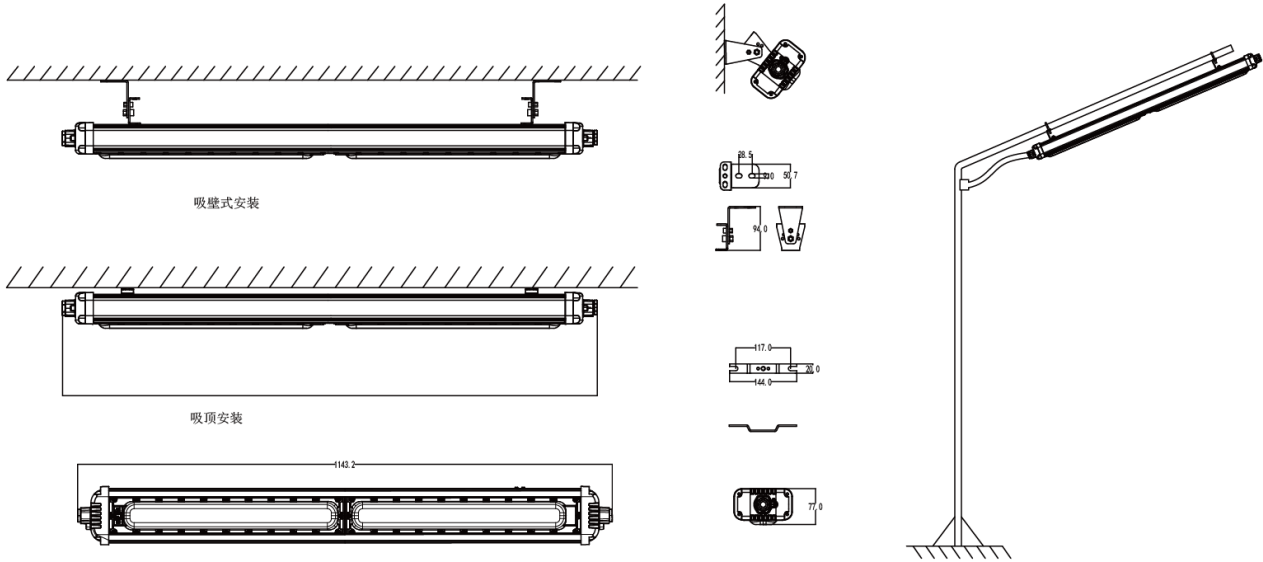

7.Packaging logistics

Name	Description	Quantity	Name	Parameter
Outer box	1200*432*292mm	8	G.W.	40.5kg
Inter box	1180*100*132mm	1	N.W	4.9kg

Doc. No.			
Version:1.0	Audit No. : 0	In Total 7 Pages	7/7

8、Caution

8.1.Installation Attentions

8.1.1.Before installation, it is necessary to check whether the actual operating conditions are in conformity with the parameters listed on the lamp nameplate.

8.1.2.Before installation, please test the lighting according to the parameters of the lamp nameplate to ensure that there is no quality problem before installation.

8.1.3.Before installation, it is necessary to determine the installation location and mode of the lamps according to the installation mode provided by the product, in combination with the on-site use environment and lighting requirements, so as to ensure that the installation is firm and reliable.

8.1.4.Connect the prepared cables with the input cables of lamps and lanterns according to the corresponding fire (brown), zero (blue) and ground (yellow-green) wires, so as to ensure that the connection is firm, and make good insulation and waterproof measures at the connection.

8.1.5.The input end of the cable can be connected to the power supply of the corresponding voltage to illuminate.

8.2.Using Attentions

8.2.1.This product is an explosion-proof product and can be used in explosion-proof places.

8.2.2.When transporting, the lamp should be installed in the carton equipped with foam shock absorption.

8.2.3.When using, the surface of the lamp has a certain temperature rise, which is a normal phenomenon.

8.2.4.The power supply voltage can work normally in the rated voltage. If the power supply voltage is too high, the lamp will be damaged; if the voltage is too low, the lamp will not start normally.

8.2.5.Lamps and lanterns must be reliably grounded.

8.3.Quality Assurance

The company has passed ISO9001:2008 international quality system audit certification, this product strictly implements ISO9001 international quality management system standard production, to ensure that the product quality fully meets national standards and design requirements.