

Explosion proof siren BBJ Series

90dB

120dB

180dB

120dB



Applications

- Widely used for alarming on various marine platforms, chemical tankers, LNG ships and dangerous cargo wharfs etc.
- Can reliably work in severe environment where is easily affected by moisture, vibration, or corrosion
- Can be used in zone 1, 2 and 21, 22
- Typical applications include:
Oil and gas industries
Chemical, petrochemical
Pharmaceutical industries
Pulp and Paper
Waste and sewage treatment
Power Generation

Standard Materials

- Housing: Die-casting aluminum
- Exterior: Stainless steel
- Globe: Tempered glass
- Gasket: Silicon rubber

Features

- Enclosure is of special aluminum alloy, powder coated surface after special corrosion-proof treatment
- Toughened glass transparent cover, stands high energy impact, with high light transmittance
- Ultra-bright LED light source, long life
- There are four light colors: red, blue, yellow and green.

Certifications

- ATEX
- CNEX
- CE
- RoHS
- ISO9001

Explosion proof siren BBJ Series

Dimensions

(In millimeter)

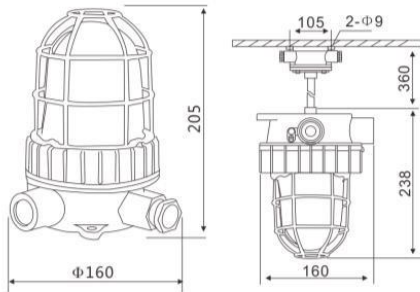

BBJ-I

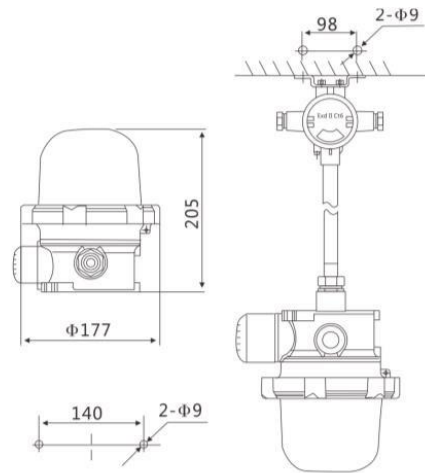

BBJ-II

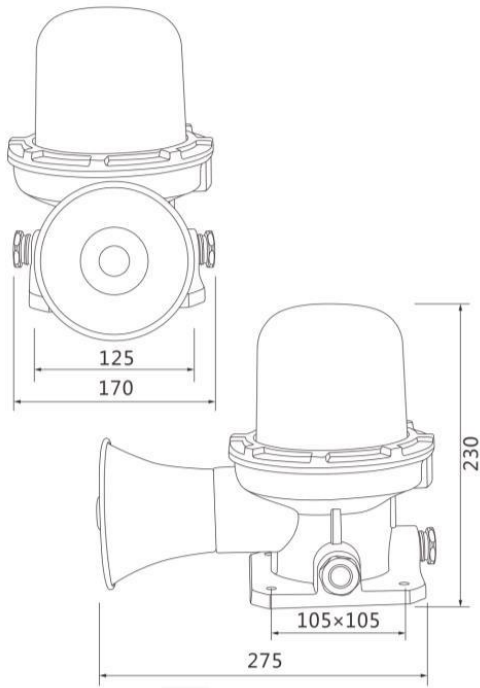

BBJ-III

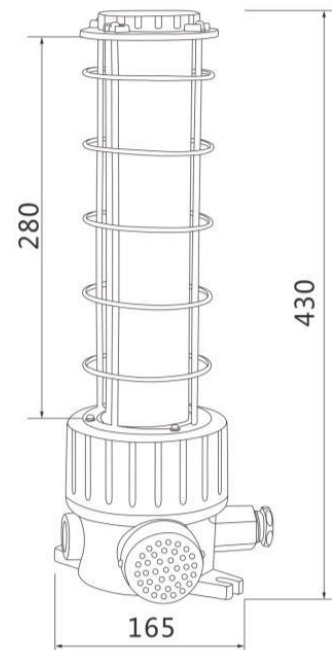

BBJ-IV

Explosion protection

Ex Marking	Ex d ib IIC T6
Classification	Group II, Category 2 GD; Class I, Division 1 and 2, Group A, B, C, D;
IP Degree	IP66
Corrosion Resistant	WF1
Input Voltage	AC220V/DC24V/ DC36V
Power	5-10W; 5W; 40W; 5W
Sound Intensity	90; 120; 180; 120
Flash Frequency	150 times/Min
Color	Red, Yellow, Blue, Green
Conduit Entries	G 3/4"
Mounting Styles	Base; Stanchion
Net Weight	1.8kg; 2.7kg; 3.7kg; 2.5kg