

Explosion Proof axial fan-CBFG series



Explosion proof

Large air volume, low noise, saving energy.

Durable and long life.

1. Explosion-proof ceiling fan consists of Ex-motor, blades and cylinder etc.
2. Air duct of explosion-proof axial flow fan is formed by welding of quality steel plate, and the fan blades are cast in aluminum alloy and with high voltage static plastic-sprayed surface.
3. Aesthetic appearance, integrate on-body assemble frame, safe and secure, with damping device and low-operating noise.
4. Conduit wiring.

Catalogue number logic

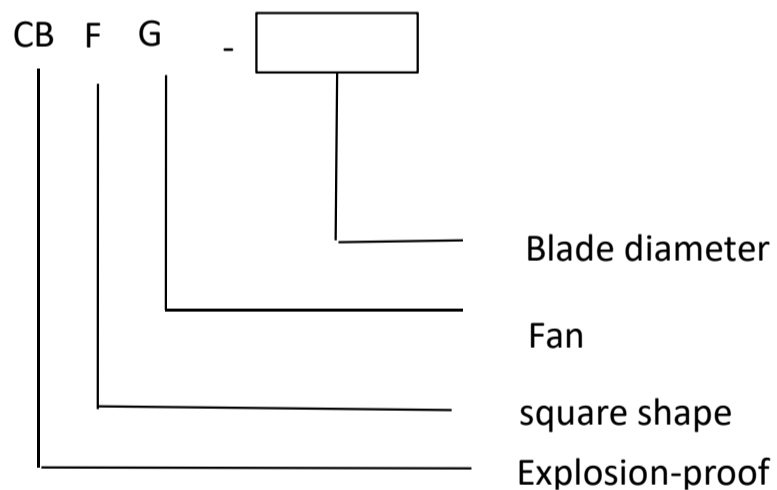

Technical data

Explosion-proof Axial Fan

CBFG

Ex Mark	Exd II BT4
Enclosure material	Iron ,Pure copper motor, Cast aluminum fan blade
Voltage	220v,380v
Type	
Blade diameter	300mm,400mm,500mm,600mm

Name	Type	Wattage (kw)	Volume (m ³ /h)	Speed (r/min)	Voltage(V)	
					220	380
Explosion proof axial fan	CBFG-300	0.12	2200	1450	220	380
	CBG-300	0.18	2400	1450	220	380
	CBFG-300	0.25	4900	1450	220	380
	CBFG-300	0.37	9500	1450	220	380

Installation size
(mm)

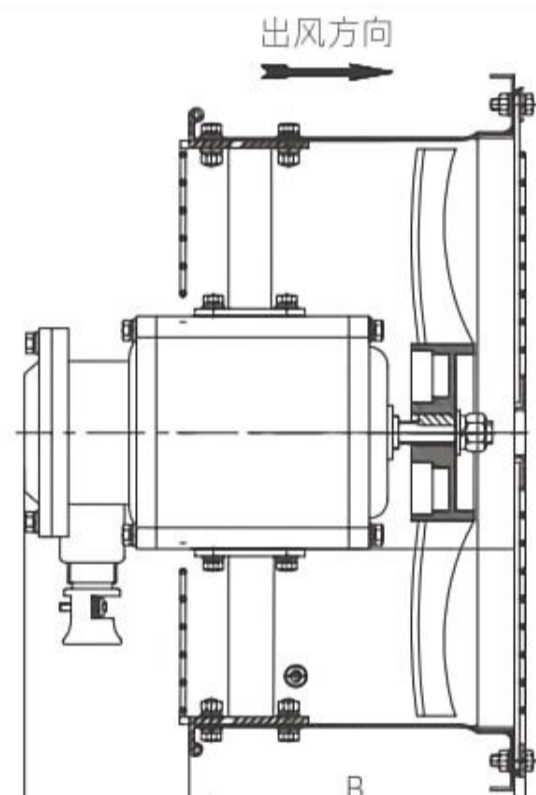
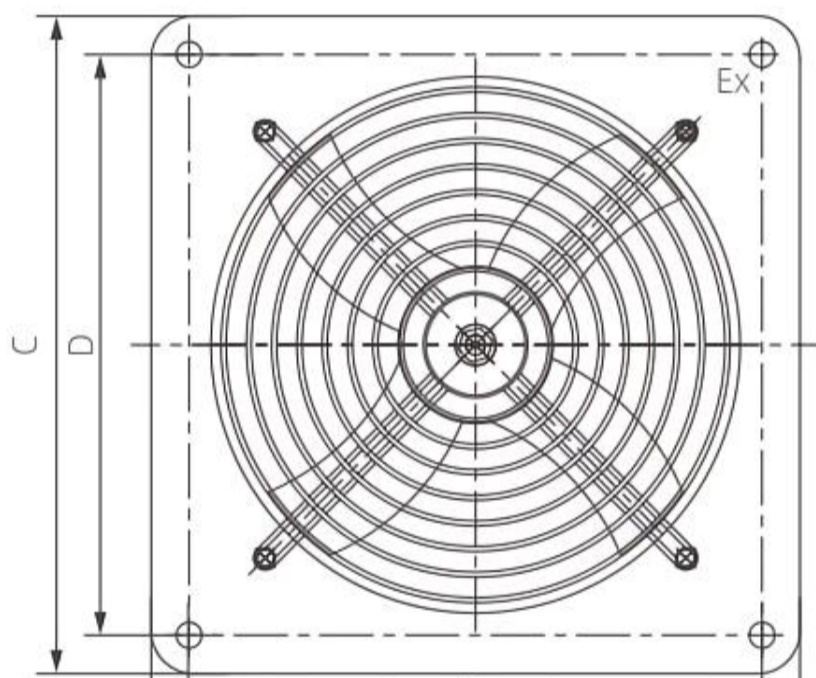

Type	A	B	C	D	Mountin g holes	Inner- diameter of duct	Flange	Blade diameter	Number of leaves	screw
300	265	175	372	340	4- φ 12	307	320	285	4	1/2
400	265	175	472	440	4- φ 12	407	420	390	3	1/2
500	275	180	572	540	4- φ 12	507	520	490	3	3/4
600	275	180	672	640	4- φ 12	607	620	590	3	3/4