

IN02-A-*

Explosion-proof Microwave Sensor

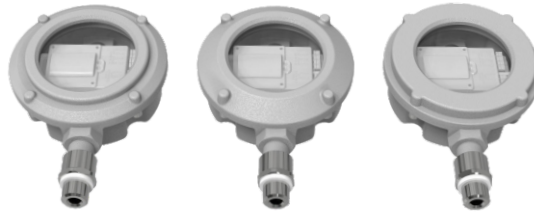

Specifications:

Model NO.	EX-IN02-A-A / EX-IN02-A-A1 EX-IN02-A-B / EX-IN02-A-B1 EX-IN02-A-C / EX-IN02-A-C1	A: Cover A made of aluminum alloy; A1: Cover A made of PC. B: Cover B made of aluminum alloy; B1: Cover B made of PC. C: Cover C made of aluminum alloy; C1: Cover C made of PC.
Input	DC Input Voltage	N/A
	Rated Voltage	AC120-277V, 50/60Hz
	No-load Power	N/A
	Stand-by Power	≤ 1W
	Surge Test	L - N: 1kV
Output	Working Mode	ON/OFF, 1-10V dimming
	Type of Load	Resistive or capacitive
	Load Capacity	120V/4.5A; 277V/2A
	Max.Power	550W
	Max. Surge Capacity	30A (50% I _{peak} , T _{width} =500uS, @230Vac full load, cold start); 60A (50% I _{peak} , T _{width} =200uS, @200Vac, full load, cold start
Dim Interface	1-10V Dimming	20mA Max., Passive 1-10V ports
	High Low Voltage Control	N/A
	PWM Control	N/A
Sensor Parameters	Operating Frequency	5.8 GHz ±75 MHz, ISM band
	Transmitting Power	0.5mW Max.
	Hold Time	5s/30s/1min/3min/20min/30min 5s/30s/1min/3min/5min/10min/20min/30min (set by remote control)
	Stand-by Period	0s/5s/5min/10min/30min/1h/+∞ 0s/10s/1min/3min/5min/10min/30min/+∞ (set by remote control)
	Detection Area	10%/75%/50%/10% 10%/75%/50%/25% (set by remote control)
	Daylight Sensor	5Lux/15Lux/30Lux/50Lux/100Lux/150Lux/Disable (ambient light diffuse state) 5lux/15lux/30lux/50lux/10 lux/150lux/Disable (set by remote control)
	Detecting Radius	2-3m @mounting height of 10m
	Mounting Height	12m Max.
	Detection Angle	150°
	Operating Environment	Operating Temperature
Storage		-40°C to +80°C/Humidity: 10%-95% (non-condensing)
Others	Input/Output Terminal	Press-type terminal block; Wire diameter: 0.75-1.5mm ²
	Material	Housing: Aluminum
	High Low Voltage Control	N/A
	IP Rating	IP66
	Protection Class	Class I, Division 2, Groups A, B, C, D
	Lifetime	50,000 hours

Note: 1. "N/A" means not available.

2. The detection area is related to the speed and volume of the moving object. This data was obtained from testing personnel with a height of 165cm and a movement speed of 0.5m/s.

IN02-A

Explosion-proof Microwave Sensor

Default Settings:

Detection Area	100%
Hold Time	5s
Stand-by Period	0s
Stand-by DIM LEVEL	10%
Daylight Sensor	Disable
Mode	On

Functions:

1. ON/OFF Function (Stand-by period set as "0s")

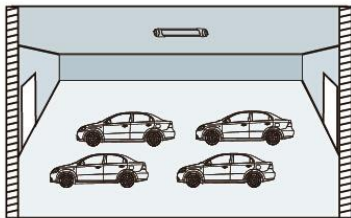

① With sufficient ambient light, the light will not be switched on even if motion is detected.

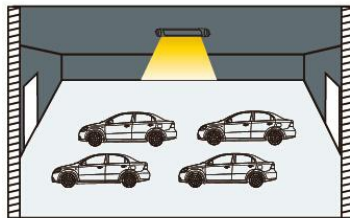

② With insufficient ambient light, the sensor switches on the light automatically when motion is detected.



③ After elapse of hold time, the sensor switches off the light if no motion is detected.

2. Two-step Dimming Function (Stand-by period set as "+∞")

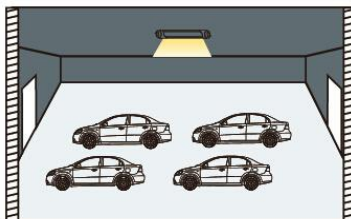

① If there is no motion detected, the light will be remained at a low light level all the time.

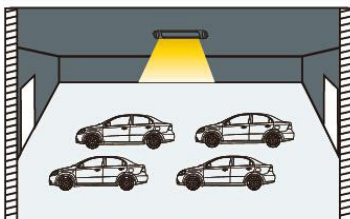

② When motion is detected, the sensor will switch on the light to 100% brightness.

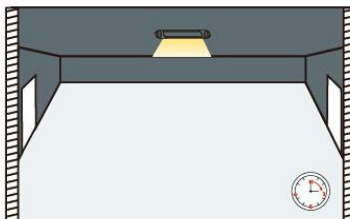

③ After elapse of hold time, the sensor dims the light at a low light level if no motion is detected.

3. Three-step Dimming Function (Stand-by period set as "5S/5min/10min/30min/1h")

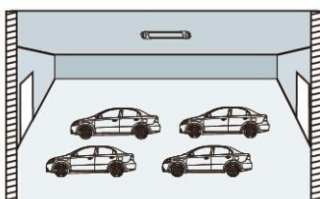

① With sufficient ambient light, the light will not be switched on even if motion is detected.

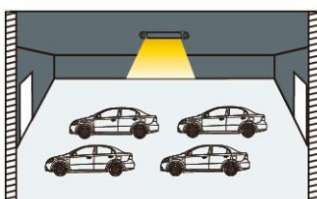

② With insufficient ambient light, the sensor switches on the light automatically when motion is detected.

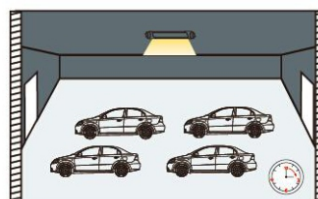

③ After elapse of hold time, the sensor dims the light at a set low light level if no new motion is detected.



④ After elapse of stand-by period, the sensor switches off the light if no motion is detected in the detection area.

IN02-A

Explosion-proof Microwave Sensor

Dimensions: mm/inch

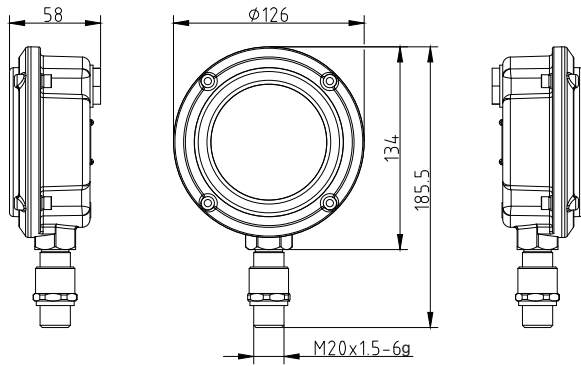

EX-IN02-A-A/
EX-IN02-A-A1

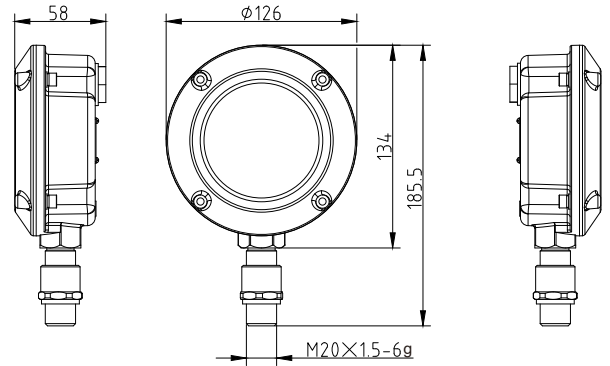

EX-IN02-A-B/
EX-IN02-A-B1

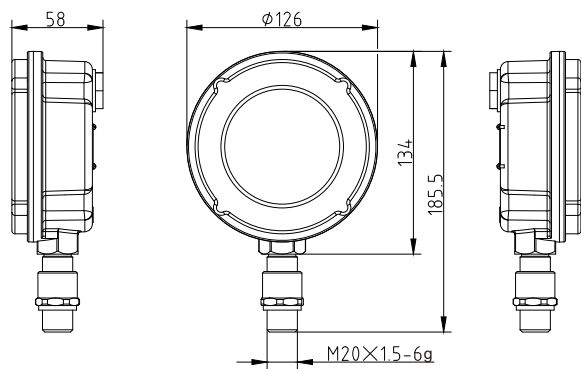

EX-IN02-A-C/
EX-IN02-A-C1

Wiring Diagram

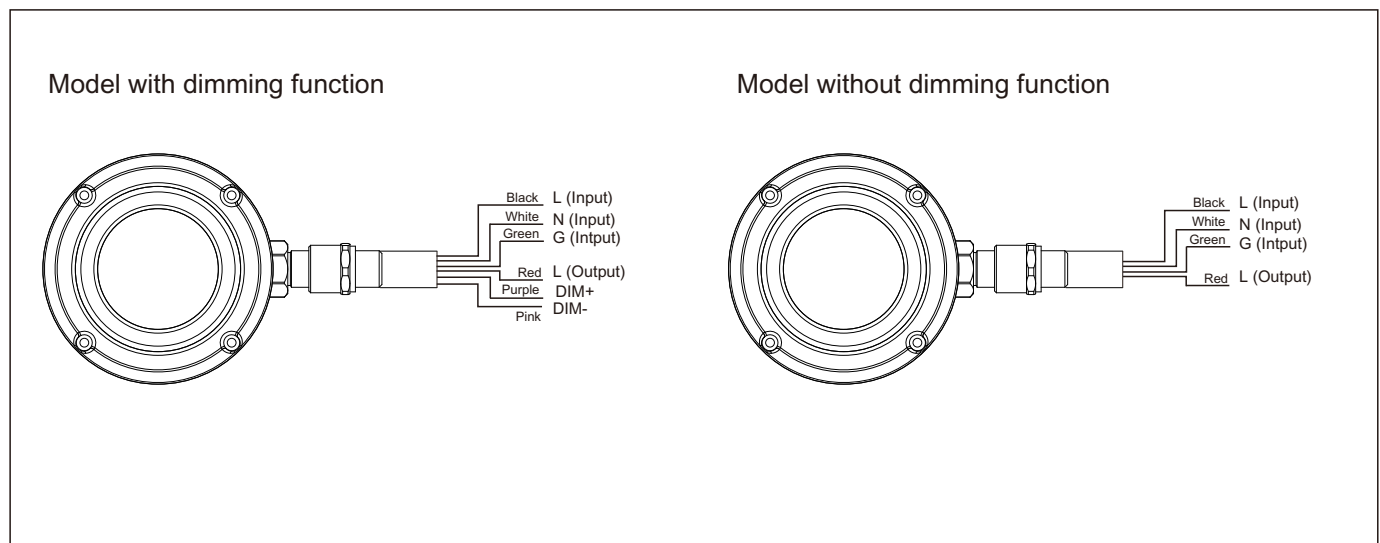

IN02-A

Explosion-proof Microwave Sensor

Radiation Pattern

(1) Ceiling Mounting

Ceiling mounted height: 10m
Sensitivity: 100%

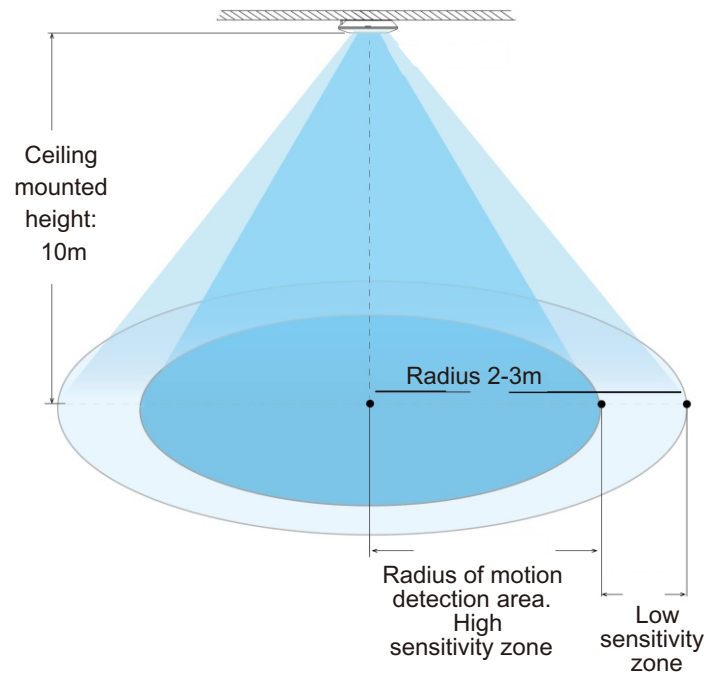
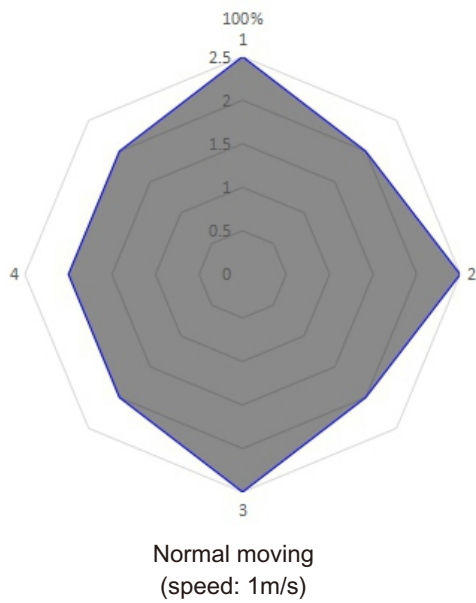

(2) Wall Mounting

Horizon mounted height: 2m
Sensitivity: 100%/75%/50%/25%

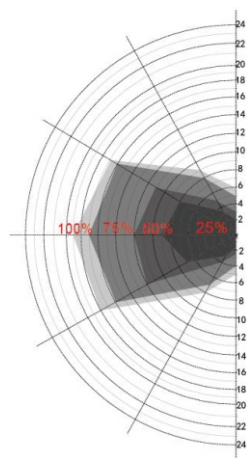

Normal moving
(speed: 1m/s)

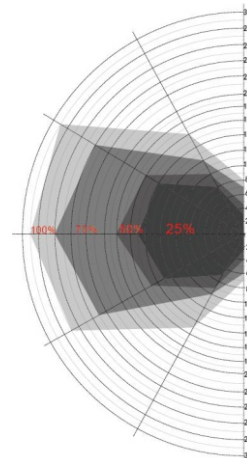

Slow moving
(speed: 0.3m/s)

IN02-A

Explosion-proof Microwave Sensor

Remote Control (Optional)

*Warning: Remote control equipment should be used in unclassified (ordinary) locations, and it is strictly prohibited to use in hazardous (classified) locations

Remote Control Setting	Button	Remarks																												
		Press the "ON/OFF" button, the light goes to constant on/off mode, sensor is disabled. Press "Reset" "Auto mode" button to quit from this mode and the sensor starts to work.																												
		Press "Reset" button, all parameters are same as setting of DIP switch or factory settings.																												
		Press "Sensor motion" button, the light quits from the constant on/off mode, and the sensor starts to work (the latest setting stays in validity).																												
		Press "DIM Test" button, the 1-10V dimming works to test whether the 1-10Vdc dimming ports are connected properly. After 2s, it returns to the latest setting automatically.																												
		Long press 3s, Daylight priority mode will be switched to daylight threshold mode, lux value will go back to previous one.																												
		Short press "DIM+/DIM-" button to set the output lumen level, each press will adjust 2% light level.																												
		Long press 3s, sensor will be switched to daylight priority mode; if preset daylight value is Disable, pressing DH Mode can not start daylight priority mode.																												
		<table border="1"> <thead> <tr> <th>Scene Options</th> <th>Detection Area</th> <th>Hold Time</th> <th>Stand-by Period</th> <th>Stand-by dim level</th> <th>Daylight Sensor</th> <th>Induction Model</th> </tr> </thead> <tbody> <tr> <td>QS1</td> <td>100%</td> <td>5min</td> <td>10min</td> <td>10%</td> <td>30Lux</td> <td>Hs</td> </tr> <tr> <td>QS2</td> <td>100%</td> <td>10min</td> <td>30min</td> <td>10%</td> <td>Disable</td> <td>Hs</td> </tr> <tr> <td>QS3</td> <td>100%</td> <td>20min</td> <td>30min</td> <td>10%</td> <td>Disable</td> <td>Hs</td> </tr> </tbody> </table>	Scene Options	Detection Area	Hold Time	Stand-by Period	Stand-by dim level	Daylight Sensor	Induction Model	QS1	100%	5min	10min	10%	30Lux	Hs	QS2	100%	10min	30min	10%	Disable	Hs	QS3	100%	20min	30min	10%	Disable	Hs
	Scene Options	Detection Area	Hold Time	Stand-by Period	Stand-by dim level	Daylight Sensor	Induction Model																							
	QS1	100%	5min	10min	10%	30Lux	Hs																							
	QS2	100%	10min	30min	10%	Disable	Hs																							
	QS3	100%	20min	30min	10%	Disable	Hs																							
		Press the "TEST 2S" button to enter the test mode any time. At the mode, the sensor parameters as follow: Detection Area is 100%, Hold Time is 5s, Stand-by Dim Level is 10%, Stand-by Period is 0s, daylight sensor disable. This function only for testing. Quit the mode by pressing "RESET" or any other function buttons.																												
		Press "HS" button to set the detection area as high sensitive. Press "LS" button to set the detection area as low sensitive. The adjustment bases on the "Detection Area" parameter you set.																												
		Daylight Sensor Set up daylight threshold: 5Lux/15Lux/30Lux/50Lux/100Lux/150Lux/Disable																												
	Stand-by period Set up stand-by time: 0S/10S/1min/3min/5min/10min/30min/+∞																													
	Hold time Set up hold time: 5S/30S/1min/3min/5min/10min/20min/30min																													
	Stand-by dim level Set up stand-by dim level: 10%/20%/30%/50%																													
	Detection Area Set up detection area: 25%/50%/75%/100%																													
	Remote Distance Toggle button to set the remote distance of remote control and sensor																													

IN02-A

Explosion-proof Microwave Sensor

Installation

1. Accessories

*Choose different adapters according to customer needs.
The following are just examples.

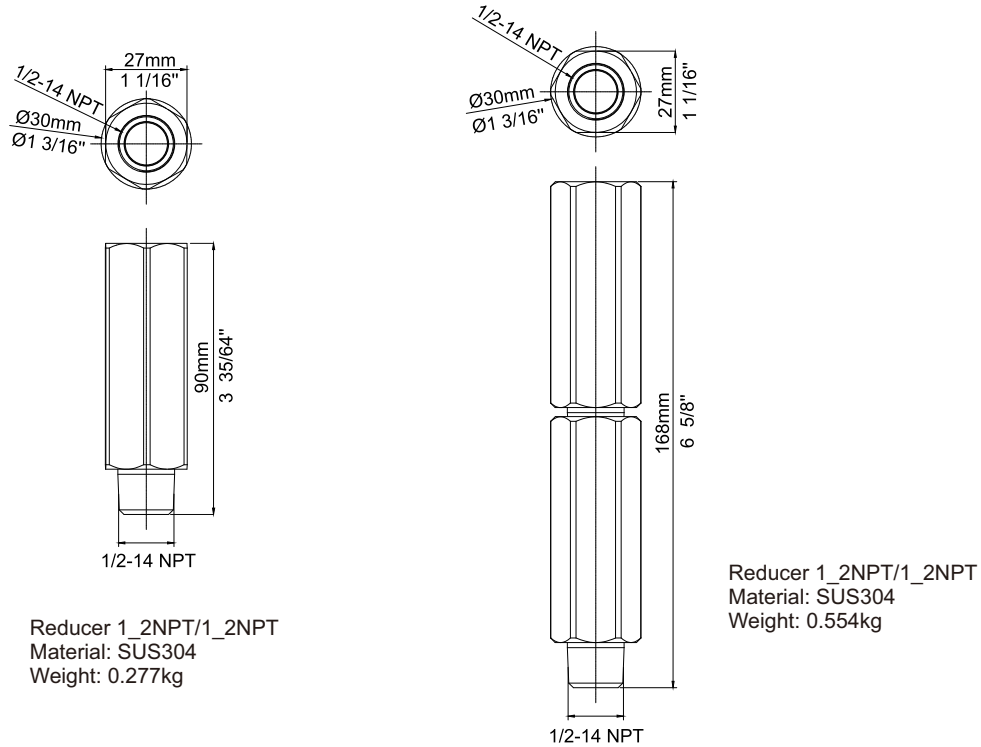

2. Operation Instructions

Step 1

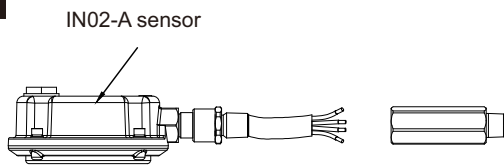

1. Thread the cables in the order shown in the figure.
Note: Increase the number of NPT1/2 reducers based on the actual installation of luminaires.

Step 2

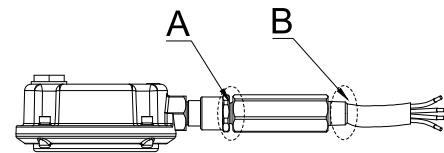

2. Fill the junction of area A and B with sealant after installation (Chico A is recommended for the sealant).

Step 3

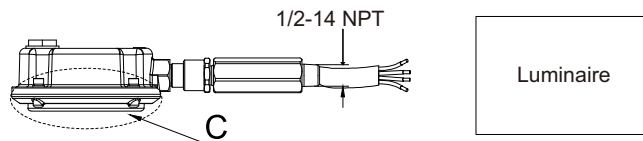

3. Select the appropriate inlet on the luminaire for connection:
Black to INPUT L, White to INPUT N, Red to OUTPUT L', Green to OUTPUT N

Note:

- a. After installation, area C should not be obstructed by any objects and should face towards detected area.
- b. Do not place the sensor close to high-density objects such as metal, glass, mixed-use walls, etc., for the sensor may be triggered by mistake.
- c. Please ensure that there are no moving signals around the sensor, such as fans, DC motors, sewers, air outlets, etc., for the sensor may generate false triggers.

IN02-A

Explosion-proof Microwave Sensor

Cautions

1. The sensor should be installed by a professional electrician. Turn off the power before installing.
2. The sensing distance will be affected by the installation height, the size of the moving object, the moving speed, and the environment.
3. The light sensitivity threshold is in a sunny environment, no shadows, and ambient light diffuse reflection conditions. Detected illuminance values may vary in different periods, climates, and environments.
4. The parameters of the sensor may need to be reconfigured in different installation environments. Contact the manufacturer for detailed information if required.
5. This sensor is only for indoor use. Outdoor use will affect the waterproof effect. Wind, rain, and surrounding moving objects may cause false triggers.
6. The distance between any installed sensors should be greater than 3m.
7. Do not place the sensor close to high-density objects such as metal, glass, concrete walls, etc. for false triggering could happen. When installed in metal lamps, metal reflective surfaces, or small enclosed environments, microwaves will be reflected multiple times and cause false triggers. Please reduce the sensitivity or contact the manufacturer for technical support.
8. Avoid installing the sensor in enclosed or semi-enclosed metal lamps for microwaves cannot penetrate metal. There should be no metal or glass covering the top of the product. Please ensure that there are no moving signals around the sensor, such as fans, DC motors, sewer pipes, air outlets, etc., for the sensor may generate false trigger.
9. It is advised to install and test 5 samples before batch installation in a new lighting project.
10. Due to continuous improvement, the contents of this instruction could be changed without prior notice.
11. This product requires a standard 0-10V dimming LED driver to achieve low-brightness function. Different power supplies may have different low-brightness effects.